



V1.5

LM40A Intelligent Peristaltic Pump

Instruction Manual

南京润泽流体控制设备有限公司
NANJING RUNZE FLUID CONTROL EQUIPMENT CO.LTD

Table of Contents

Chapter 1 Product Introduction.....	4
1.1 Overview.....	4
1.2 Product Features.....	4
Chapter 2 Port and Structure Description.....	5
2.1 Product Technical Parameters.....	5
2.2 Diagram of Overall structure.....	5
2.3 Definition of Communication Interface.....	6
2.4 Pump Head/Tube Selection.....	7
Chapter 3 Keyboard Control Mode.....	8
3.1 Man-Machine Interface.....	8
3.1.1 LED Indicator Light Meaning.....	8
3.1.2 Key Function.....	8
3.1.3 Rotary Encoder Function.....	9
3.2 Working Mode Description.....	9
3.2.1 Keyboard Control Mode.....	9
3.2.2 Communication Control Mode.....	10
3.2.3 External Control Mode.....	10
Chapter 4 Communication Control Mode.....	11
4.1 Long Command/Reply Format.....	11
4.2 Short Command/Reply Format.....	12
4.3 Factory Setting Command/ Reply Format.....	12
4.4 Command List.....	13
Chapter 5 External Control Mode.....	16

5.1 External Control Mode.....	16
5.2 External Control Speed Module.....	16
5.3 Maximum Speed Setting.....	17
5.4 Foot Pedal Control Mode.....	17
Chapter 6 Technical Parameters of Peristaltic Pump Tube.....	19
6.1 Peristaltic Pump Head-Tube Reference Flow Curve.....	19
Chapter 7 Equipment Maintenance.....	22
7.1 Common Equipment Maintenance Process.....	22
7.2 Common Problems and Solutions.....	22
Chapter 8 Version Description.....	23
Chapter 9 Technical Service.....	24

Chapter 1 Product Introduction

1.1 Overview

The LM40A peristaltic pump uses a cost-effective processor to control the stepper motor, and uses multiple independent LEDs to display the status (including positive/negative rotation, foot pedal mode F1/F2, motor movement/motor stop, external control trigger, etc.).

1.2 Product Features

The product can be adjusted the speed by keyboard panel or rotary encoder. The LED displays the positive/negative rotation, foot switch status, whether the motor is running, whether the external control interface is effective, etc. The display is intuitive, the operation is easy & convenient, and the content is simple. Motor subdivision is adaptive and speed control accuracy can reach $\pm 0.1\text{rpm}$; The product support rich application scenarios, keyboard control mode, RS485 communication control mode, external control mode (Multiple signal conversion modules are optional) and passive contact output for motor working status.

Chapter 2 Port and Structure Description

2.1 Product Technical Parameters

Name	Specification
Range of speed	0.1rpm ~ 300/400.0rpm (The maximum speed varies slightly depending on different pump heads or tubes .)
Speed accuracy	±0.1rpm
Flow rate	0.027~1380 ml/min
Foot pedal input interface	Foot switch controls start and stop (keyboard control mode only)
External control speed signal input interface	Support multiple switch control input (keyboard control mode only)
External control steering signal input interface	Support steering switching control inputs (external control mode or foot pedal control mode only)
External control start signal input interface	Support start/stop switch control input(external control mode only)
Communication control	RS485 (communication control mode only)
Power supply	DC24V±10%
Power consumption	35W
Working environment	Temperature 0 ~ 40C° Relative humidity < 80%
Dimension	208.8(length)×126.9(width)×152.7(height) (mm)
Weight	1.64Kg
Protection level	IP31

2.2 Diagram of Overall structure

The product is composed of body, pump head, pump tube, etc.

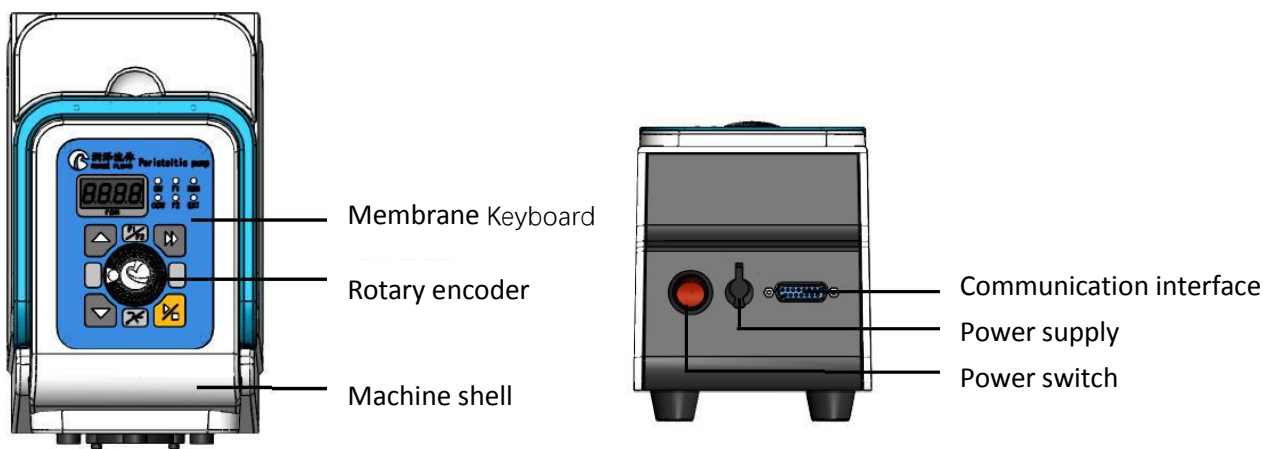

Figure 2-1 Diagram of LM40A Intelligent Filling Peristaltic Pump

2.3 Definition of Communication Interface

No.	Attribute	Meaning
1	+24V	DC24V power output (only used with external interface)
2	EXT-EN	External control enable signal (external control function takes effect when grounded)
3	EXT-DIR	External control steering signal (take effect when external control is effective or foot pedal is effective)
4	COM	Passive contact common end
5	COM-GND	ADC-IN GND
6	FT-EN	Foot switch enable signal interface (foot pedal control takes effect when grounded)
7	CK	Passive contact output-normally open state
8	FT-SW	Foot switch input signal interface (used with F1/F2 keys)
9	GND	Ground wire
10	EXT-ST	External control trigger signal input interface (take effect when external control is effective)
11	A	RS485- port A
12	B	RS485- port B
13	SWD-DIO	SWD-DIO interface
14	SWD-CLK	SWD-CLK interface
15	ADC-IN	External control speed input interface (3.3V interface)-used with dedicated conversion module.

Table 2-1 DB15 External Terminal Attribute Definition

2.4 Pump Head/Tube Selection

Type	Pump head	Head color	roller	Max, flow rate					
				14#	16#	25#	17#	15#	24#
LM40A	YZ1515X-3B	white	3	108 (400rpm)	385 (400rpm)	750 (300rpm)	1385 (300rpm)		
	YZ1515X-3H	black	3						
	YZ1515X-6B	white	6	84 (400rpm)	265 (400rpm)				
	YZ1515X-6H	black	6						
	YZ2515X-3B	white	3						1322 (400rpm)
	YZ2515X-3H	black	3						
	SN15-3	translucent	3	77 (300rpm)	285 (300rpm)	600 (300rpm)	1097 (300rpm)		
	SN15-6	translucent	6	48 (300rpm)	180 (300rpm)				
	SN25-3	translucent	3					551 (300rpm)	

Table 2-2 Model of Pump Head/Tube and Corresponding Max. Flow Reference

Note: (1) When selecting pump head and pump tube, refer to chapter 6 flow curve.

(2) The flexible tubes with same specification vary in the ductility, resilience and hardness due to different materials. Maximum flow rate is for reference only.

Chapter 3 Keyboard Control Mode

3.1 Man-Machine Interface



3.1.1 LED Indicator Light Meaning





Name	LED status definition
CW	The indicator light is on, indicating that the current rotation of the peristaltic pump motor is clockwise by default. (Note 1)
CCW	The indicator light is on, indicating that the current rotation of the peristaltic pump motor is counterclockwise by default. (Note 1)
F1	The indicator light is always on, indicating that the current foot switch trigger mode is continuous mode by default. (Note 2)
F2	The indicator light is always on, indicating that the current foot switch trigger mode is inching mode by default. (Note 2)
RUN	The indicator light is always on, indicating that the motor is in running. The indicator light flashes slowly (1 second on and 1 second off), indicating that the motor is stopped and the software is running. The indicator light flashes quickly (0.1 second on and 0.1 second off), indicating that the motor is running at full speed and the software is running.
EXT	The indicator light is on, indicating the motor is in external control mode currently, and the control of the motor operation is determined by the external control mode status.

Note 1: The direction of backflash rotation is opposite to that of CW/CCW.

Note 2: One of the CW/CCW indicator lights will be on only when the matching foot switch is connected correctly.

3.1.2 Key Function

Name	Key function	Key result
	Speed increase	When the motor is stopped, change the default speed; when the motor is rotating, increase the dynamic speed; After pressing it for 1 second keep it pressed to achieve a rapid increase in speed. (Note 1) Reuse for increasing setting of suction angle.
	Speed decrease	When the motor stops, change the default speed; when the motor is rotating, decrease the dynamic speed; after pressing it for 1 second keep it pressed to achieve a rapid decrease in speed. (Note 1) When reused, it is the decrease setting of suction angle.
	CW/CCW switching	When the motor stops, change the default direction of rotation; when the motor rotates, change the direction of rotation immediately. Corresponding CW/CCW indicator lights switch.

	Full-speed key	When it stops or runs continuously, switch to full-speed status; when in full-speed, return to the status before full-speed. (Note 2)
	ON/OFF key	Control the start and stop of the motor manually.
F1/F2	Foot pedal switch mode indication	When the matched foot pedal switch is effectively connected, press the F1/F2 key to switch the working mode, corresponding F1/F2 indicator lights switch (F1 means continuous operation, F2 means jog operation); if the foot pedal switch is not connected, it cannot switch.
	Multifunction key	When the motor stops, press the blank key to switch to the suction angle editing interface, press the up and down keys to change the value of the suction angle, and press the blank key again to save the current value; when the motor runs normally, press the blank key to save the current dynamic speed; when the motor is running at full speed, this key is invalid. (Note 1)
	Mute key	Pressing this key can mute the sound or enable the buzzer.

Note 1: When at full speed, this key is invalid.

Note 2: When at full speed, the RUN indicator light flashes quickly.

3.1.3 Rotary Encoder Function

Name	Key function	Key result
Ⓜ	Multifunction key	Reuse as a start/stop key.
○	Rotary encoder rotation	used to change the speed/the suction angle.

3.2 Working Mode Description

3.2.1 Keyboard Control Mode

The keyboard can control the start and stop of the peristaltic pump, control the increase and decrease of the speed, and realize full speed with one-key.

Foot switch control mode: Continuous mode (F1) and Inching mode (F2).

Continuous mode: Step on pedal switch and release to start peristaltic pump, then step again and release to stop peristaltic pump.

Inching mode: When the foot switch keeps is stepped and held, the peristaltic pump keeps rotating; when it is released, the peristaltic pump stops.

3.2.2 Communication Control Mode

Through the RS485 communication interface, control the start and stop of the peristaltic pump. Run step by step or in circles.

3.2.3 External Control Mode

With the external control module connected, the EXT indicator light is on. Steering can be controlled by the external steering signal; Start and stop can be controlled by the trigger signal and the speed can be controlled by changing the input analog signal.

(1) Current code: The current code is used to set the maximum current of the motor.

The table of current code definition is as follows:

Current code	Motor max. output current (A)	Motor effective output current (A)	Current code	Motor max. output current (A)	Motor effective output current (A)
4	1.01	0.72	18	3.86	2.73
5	1.21	0.86	19	4.06 (Note 2)	2.87
6	1.42	1.00	20	4.27	3.02
7	1.63	1.15	21	4.47	3.16
8	1.83	1.29	22	4.67	3.30
9	2.03	1.44	23	4.88	3.45
10	2.24	1.58	24	5.08	3.59
11	2.44	1.73	25	5.28	3.73
12	2.64	1.87	26	5.49	3.88
13	2.85	2.02	27	5.69	4.02
14	3.05	2.16	28	5.89	4.17
15	3.25	2.30	29	6.10	4.31
16	3.46	2.45	30	6.30	4.47
17	3.66	2.59	31	6.50	4.60

Table 3-1 Comparison Table of Current Code and Motor Current

Note 1: Hardware default current code value of LM40A

Chapter 4 Communication Control Mode

Note: our special debugging assistant serial Comm V1.3.0 is required for control.

4.1 Long Command/Reply Format

Byte send:

1	2	3	4	5	6	7	8	9	10
FH (frame header)	Address code	Function code	Function parameter				EOF (end of frame)	CUCUM (cumulative sum)	
STX	ADDR	FUNC	1-8bit	9-16bit	17-24bit	25-32bit	ETX	Low byte	High byte

The 1st byte STX : Frame header (0xCC)

The 2nd byte ADDR : Slave address (0x01 ~ 0xF7)

Multicast address (0x80~0xFE) Broadcast address (0xFF)

The 3rd byte FUNC : Function code

The 4th-7th byte : Parameters corresponding to the function code

The 8th byte ETX : End of frame (0xDD)

The 9th-10th byte : Cumulative sum check code from byte 1 to 8

Byte return:

1	2	3	4	5	6	7	8	9	10
FH (frame header)	Address code	Status code	Status parameter				EOF (end of frame)	CUCUM (cumulative sum)	
STX	ADDR	STATE	1-8bit	9-16bit	17-24bit	25-32bit	ETX	Low byte	High byte

The 1st byte STX : Frame header (0xCC)

The 2nd byte ADDR : Slave address (0x00 ~ 0xF7)

Multicast address (0x80~0xFE) Broadcast address (0xFF)

The 3rd byte STATE : Status code

The 4th-7th byte : Parameters corresponding to the status code

The 8th byte ETX : End of frame (0xDD)

The 9th-10th byte : Cumulative sum check code from byte 1 to 8

4.2 Short Command/Reply Format

Byte send:

1	2	3	4	5	6	7	8
FH (frame header)	Address code	Function code	Function parameter		EOF (end of frame)	CUCUM (cumulative sum)	
STX	ADDR	FUNC	1-8 bit	9-16 bit	ETX	Low byte	High byte

- The 1st byte STX : Frame header (0xCC)
- The 2nd byte ADDR : Slave address (0x00 ~ 0xF7)
 Multicast address (0x80~0xFE) Broadcast address (0xFF)
- The 3rd byte FUNC : Function code
- The 4th-5th byte : Parameters corresponding to the function code
- The 6th byte ETX : End of frame (0xDD)
- The 7th-8th byte : Cumulative sum check code from byte 1 to 6

Byte return:

1	2	3	4	5	6	7	8
FH(frame header)	Address code	Status code	Status parameter		EOF (end of frame)	CUCUM (cumulative sum)	
STX	ADDR	STATE	1-8 bit	9-16 bit	ETX	Low byte	High byte

- The 1st byte STX : Frame header (0xCC)
- The 2nd byte ADDR : Slave address (0x00 ~ 0xF7)
 Multicast address (0x80~0xFE) Broadcast address (0xFF)
- The 3rd byte STATE : Status code
- The 4th-5th byte : Parameters corresponding to the status code
- The 6th byte ETX : End of frame (0xDD)
- The 7th-8th byte : Cumulative sum check code from byte 1 to 6

4.3 Factory Setting Command/ Reply Format

Byte send:

1	2	3	4-7	8	9	10	11	12	13	14
FH frame header)	Address code	Function code	Code	Function parameter				EOF (end of frame)	CUCUM (cumulative sum)	
STX	ADDR	FUNC		1-8 bit	9-16 bit	17-24 bit	25-32 bit	ETX	Low byte	High byte

- The 1st byte STX : Frame header (0xCC)
- The 2nd byte ADDR : Slave address (0x00 ~ 0xF7)
 Multicast address (0x80~0xFE) Broadcast address (0xFF)
- The 3rd byte FUNC : Function code
- The 4th-7th byte : Code, fixed as 0xAABBEEFF, little-endian mode
- The 8th-11th byte : Parameters corresponding to the function code
- The 12th byte ETX : End of frame (0xDD)
- The 13th-14th byte : Cumulative sum check code from byte 1 to 12

Byte return:

1	2	3	4	5	6	7	8
FH (frame header)	Address code	Status code	Status parameter		EOF (end of frame)	CUCUM (cumulative sum)	
STX	ADDR	STATE	1-8 bit	9-16 bit	ETX	Low byte	High byte

- The 1st byte STX : Frame header (0xCC)
- The 2nd byte ADDR : Slave address (0x00 ~ 0xF7)
 Multicast address (0x80~0xFE) Broadcast address (0xFF)
- The 3rd byte STATE : Status code
- The 4th-5th byte : Parameters corresponding to the status code
- The 6th byte ETX : End of frame (0xDD)
- The 7th-8th byte : Cumulative sum check code from byte 1 to 6

4.4 Command List

No.	Function code	Function	Parameter	Remark
1	0x00	Set address command	Parameter range is 0x01~0xF7	Factory dedicated command
2	0x02	Set RS485 baud rate	Parameter range is 0x00-0x04 0x00 corresponding baud rate is 9600bps 0x01 corresponding baud rate is 19200bps 0x02 corresponding baud rate is 38400bps 0x03 corresponding baud rate is 57600bps 0x04 corresponding baud rate is 115200bps	Factory dedicated command
3	0x04	Set (software) current command	Parameter range is 0-31, representing 0.2-6.5A	Factory dedicated command
4	0x05	Set current setting source	0- determined by hardware, 1- determined by software	Factory dedicated command

5	0x06	Set one-key full speed	Parameter range is 0x03E8 (0.1~400rpm) . Maximum speed (100.0 to actual maximum speed) ten times storage, fixed parameter 0x0FA0 (400.0rpm)	Factory dedicated command
6	0x07	Set maximum speed	Parameter range is 0x03E8-0x0FA0, (100.0~400.0rpm) , 10 times storage, fixed parameter 0x0FA0 (400.0rpm)	Factory dedicated command
7	0x08	Set suction angle	Parameter range is 0x00-0x0E10 (0~360°) 0 times storage, fixed parameter 0x00	Factory dedicated command
8	0x09	Set Multicast address	Parameter range (0x80~0xFE)	Factory dedicated command
9	0x20	Query address command	Parameter range is 0x01-0xF7, not match address	Compatible with long command/short command
10	0x22	Query RS485 baud rate	Parameter range is 0x00-0x04 0x00 corresponding baud rate is 9600bps 0x01 corresponding baud rate is 19200bps 0x02 corresponding baud rate is 38400bps 0x03 corresponding baud rate is 57600bps 0x04 corresponding baud rate is 115200bps	Compatible with long command/short command
11	0x23	Query (hardware) current command	Parameter range is 0x05/0x0F/0x13/0x17/0x1B/0x1F, representing 1.21A/3.25A/4.06A/4.88A/5.69A/6.50A	Compatible with long command/short command
12	0x24	Query (software) current command	Parameter range is 0-31, representing 0.2-6.5A	Compatible with long command/short command
13	0x25	Query current source	0-determined by hardware dialing code selection (default), 1-determined by software setup command	Compatible with long command/short command
14	0x26	Set one-key full speed	Parameter range is 0x03E8-0x0FA0 (100.0~400.0rpm) , 10 times storage, fixed parameter is 0x0FA0 (400.0rpm)	Compatible with long command/short command
15	0x27	Query maximum speed	Parameter range is 0x03E8-0x0FA0 (100.0~400.0rpm) , 10 times storage, fixed parameter is 0x0FA0 (400.0rpm)	Compatible with long command/short command
16	0x28	Query suction angle	Parameter range is 0x00-0x0E10 (0~360°) 0 times storage, fixed parameter 0x00	Compatible with long command/short command
17	0x29	Query Multicast address	Parameter range (0x80~0xFE)	Compatible with long command/short command

18	0x40	Run a few steps clockwise	00000001H-FFFFFFFFH (long command) 0001H-FFFFH (short command)	Compatible with long command/ short command
19	0x41	Run a few steps counterclockwise	0x00000001-0xFFFFFFFF (long command) 0001H-FFFFH (short command)	Compatible with long command/ short command
20	0x42	Run a few circles clockwise	0x00000001-0xFFFFFFFF (long command) 0x0001-0xFFFF (short command)	Compatible with long command/ short command
21	0x43	Run a few circles counterclockwise	0x00000001-0xFFFFFFFF (long command) 0x0001-0xFFFF (short command)	Compatible with long command/ short command
22	0x47	rotate clockwise continuously	Parameters can be random.	Compatible with long command/ short command
23	0x48	rotate counterclockwise continuously	Parameters can be random.	Compatible with long command/ short command
24	0x49	Stop forcibly	Parameters can be random.	Compatible with long command/ short command
25	0x4A	Query motor status	Parameters can be random. Reply the current dynamic speed.	Compatible with long command/ short command
26	0x4B	Set dynamic speed	0x0001~0x0FA0 (0.1~400rpm) , 10 times storage, fixed parameter is (1~4000)	Compatible with long command/ short command
27	0x4C	Query dynamic speed	Parameters can be random. Reply the current dynamic speed.	Compatible with long command/ short command
28	0x4D	Query motor remaining steps	Parameters can be random. Use short command to query and reply low 16 bits of steps left.	Compatible with long command/ short command
29	0x4E	Query motor remaining circles	Parameters can be random. Use short command to query and reply low 16 bits of circles left.	Compatible with long command/ short command

Note:

1. The parameter ranges of the above long commands/short commands are different. The long commands support 32-bit parameters, and the short commands support 16-bit parameters.
2. Factory commands are generally not required to be used, and relatively suitable parameters have been defaulted by the factory. It is only used under special circumstances.

Chapter 5 External Control Mode

5.1 External Control Mode

(1) When external control module is plugged in, the EXT external control indicator lights on and the machine switches to external control mode automatically.

(2) Under external control mode, keyboard control is not supported; When the external control mode is removed, the machine will switch to the keyboard control mode automatically.

(3) Under external control mode, steering control, triggering start and stop and speed adjustment are supported.

EXT-DIR, no matter when the motor stops or runs, the direction of rotation can be switched. If EXT-DIR signal is floating or high, it means positive rotation, and if EXT-DIR is low (GND short-circuit), it means negative rotation.

EXT-ST, (The wire jumper determines whether to turn on the start/stop switch). Suspended or high Ext-ST signal means stop, and low Ext-ST (short circuit with GND) means start

ADC-IN, it determines the rotation speed. Actually applied external input signal, which might be 0-5V, 0-10V, 4-20mA or 0-10KHz, etc., finally convert to 0-3.3V by the external control module, and the voltage has a linear relationship with the speed.

5.2 External Control Speed Module

Type of external control speed signal	Remark
0-3.3V external control speed	The voltage signal of 0~3.3V is directly applied to the ADC-IN port.
0-5V/10V external control speed	Require 0~5V/10V to 0~3.3V dedicated conversion module.
0-10V external control speed	Require 0~10V to 0~3.3V dedicated conversion module.
4-20mA external control speed	Require 4~20mA to 0~3.3V dedicated conversion module.
0-10KHz external control speed	Require 0~10KHz to 0~3.3V dedicated conversion module.

Note: External control speed will correspond to the range from 0 to maximum speed. Due to the error of AD collection, the actual minimum speed will be greater than 0.1rpm, and the actual maximum speed will be less than the theoretical set maximum speed

5.2.1 0-5V /10V external control speed module Schematic diagram

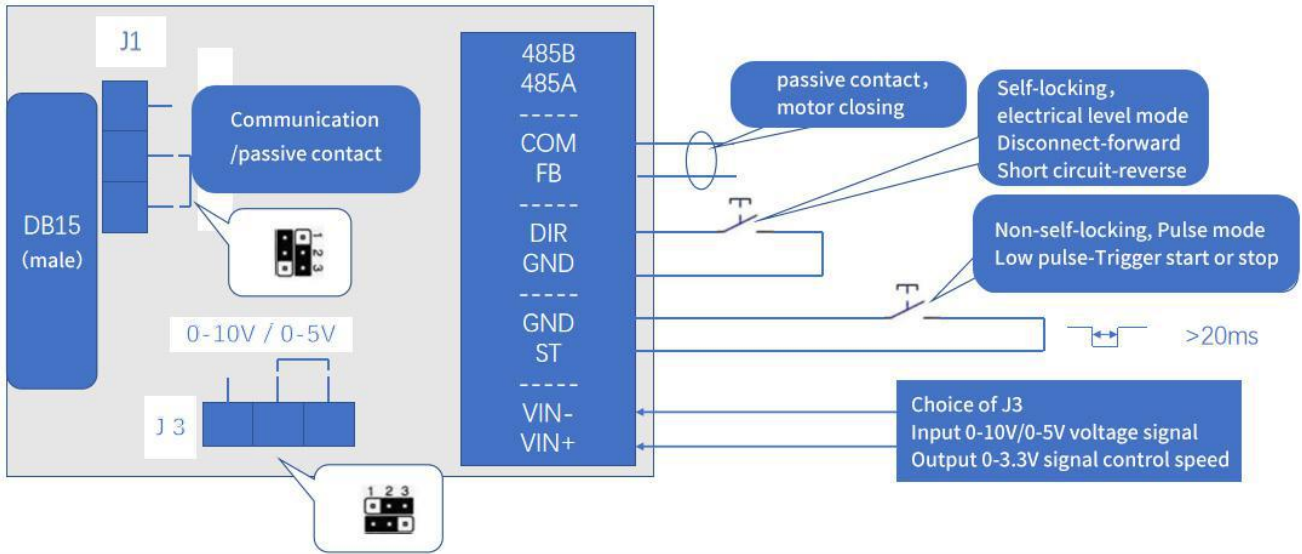

5.2.2 4-20mA external control speed module Schematic diagram

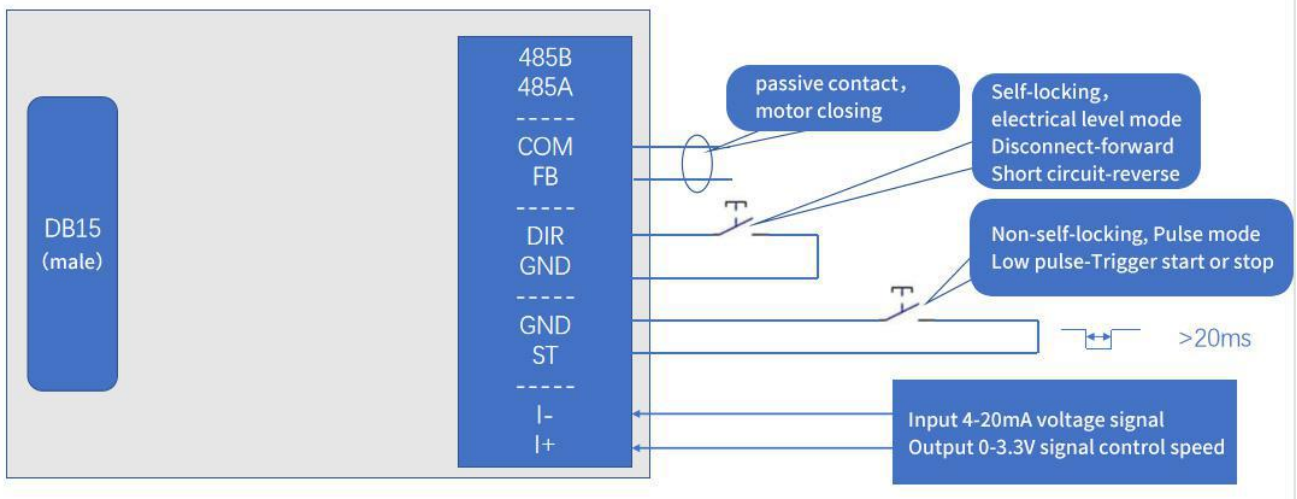

5.3 Maximum Speed Setting

The maximum speed is set through RS485 when the motor stops, see the 0x07 command in chapter 4.4.

When the instrument leaves the factory, the appropriate maximum speed will be preset according to the pump head/pump tube. The user does not need to set.

5.4 Foot Pedal Control Mode

(1) Plug in the dedicated pedal module. One of the pedal mode indicators (F1/F2) lights on, and the machine switch to pedal control mode automatically.

(2) In the foot pedal control mode, keyboard control is supported, but it is the pedal switch that determines the final running status of the motor. That is, in F1 mode, the pedal can start and stop the motor, or the keyboard can start and stop the motor; in F2 mode, the status of the pedal switch plays a decisive role, and pressing the key at this time will interfere with the execution effect of the foot pedal.

(3) In the foot pedal control mode, the suction angle is effective when the motor stops.

(4) In the foot pedal control mode, the veer key is valid, and EXT-DIR is also valid.

EXT-DIR, No matter when the motor stops or runs, the direction of rotation can be switched. If EXT-DIR signal is floating or high, it means positive rotation, and if EXT-DIR is low (GND short-circuit), it means negative rotation.

FT-EN If the signal is suspended or high, the pedal is disabled, and if the signal is low (GND short-circuit), it is enabled.

FT-SW If the signal is suspended or high, the motor stops under foot pedal mode, and if the signal is low (short circuit with GND), the motor runs.

(5) When the foot pedal switch is removed, the machine will switch to the keyboard control mode automatically. F1/F2 indicator lights off.

Chapter 6 Technical Parameters of Peristaltic Pump Tube

6.1 Peristaltic Pump Head-Tube Reference Flow Curve

(1) YZ1515X-3 rollers (LM40A) pump head flow-speed curve

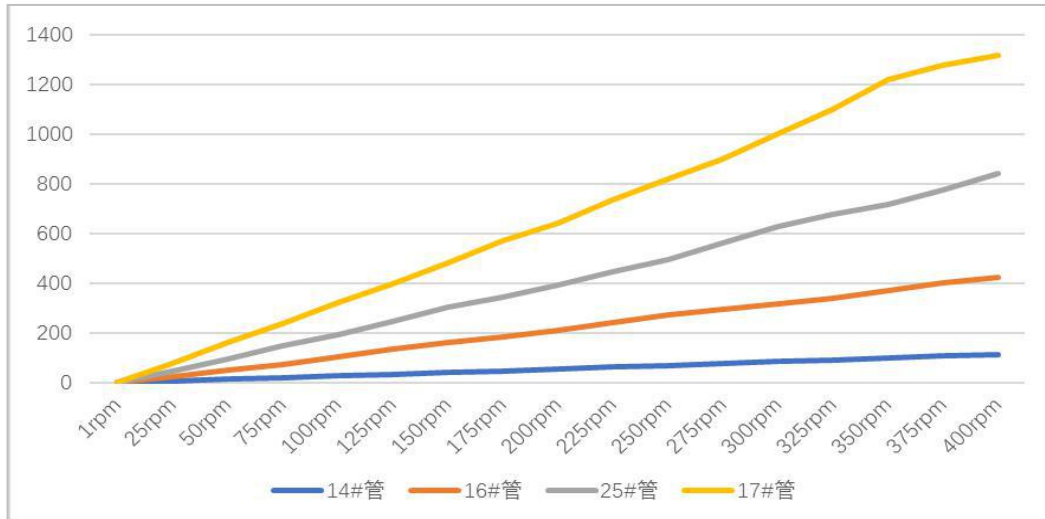

Figure 6-2-1 YZ1515X-3 Rollers Flow-Speed Curve

(2) YZ1515X-6 rollers (LM40A) pump head flow-speed curve

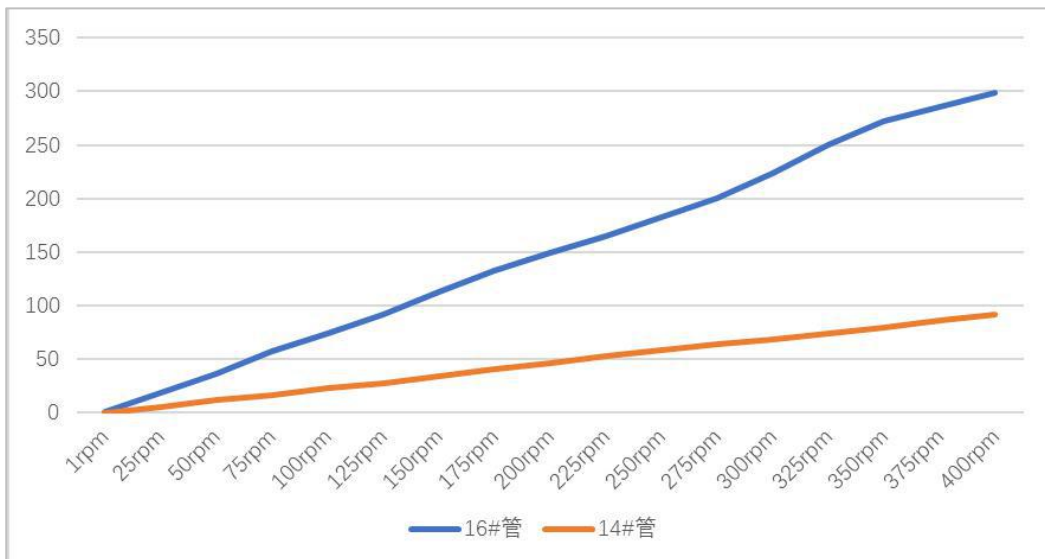

Figure 6-2-2 YZ1515X-6 Rollers Flow-Speed Curve

(3) SN15-3 rollers (LM40A) pump head flow-speed curve

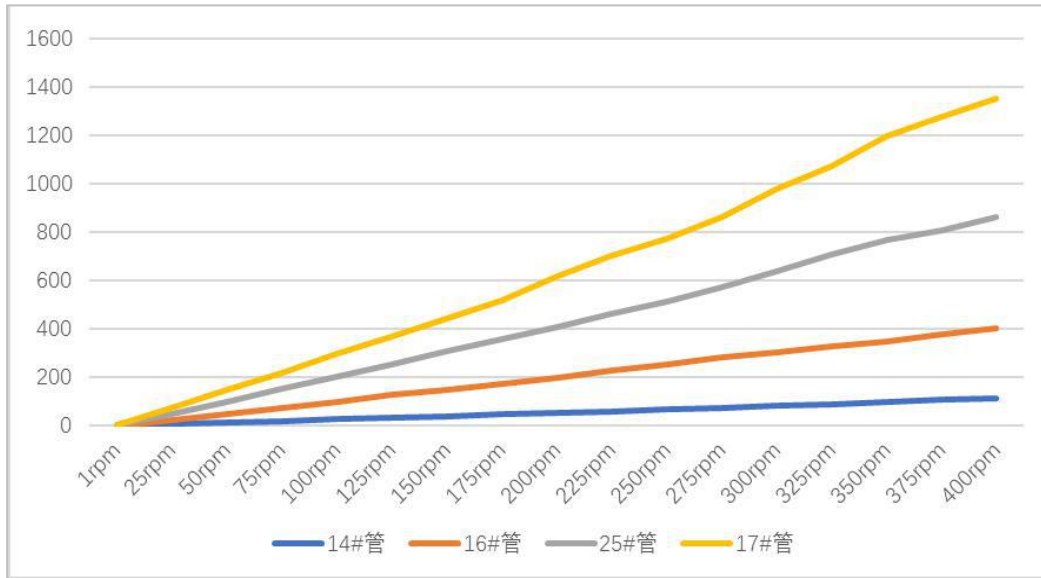

Figure 6-2-3 SN15-3 Rollers Flow-Speed Curve

(4) SN15-6 rollers (LM40A) pump head flow-speed curve

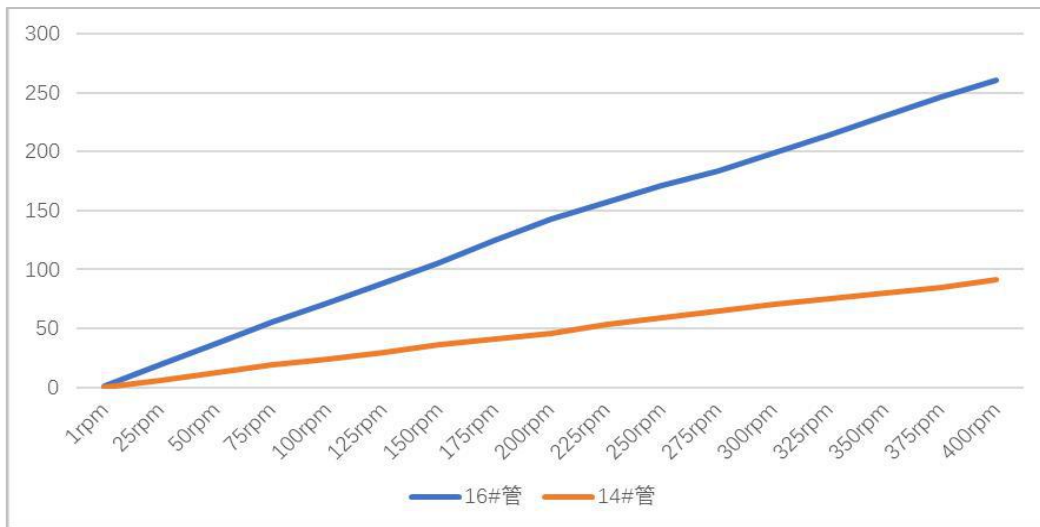

Figure 6-2-4 SN15-6 Rollers Flow-Speed Curve

Note 1: The above "flow-speed" of different pump heads and different tubes is the actual test curve, without any modification, for reference only;

Note 2: The above tested liquid is water under normal temperature conditions, and the test temperature is about 25°C;

Note 3: There are many factors that affect the actual test value, including the material and elasticity of the tube, the tightness of the tube installation, the viscosity of the test liquid, etc.

Note 4: The diameter and wall thickness of the tube affect the maximum speed of the actual pump head when stably running;

Note 5: If you have higher requirements for dosing accuracy, please choose other products such as the syringe pump.

Chapter 7 Equipment Maintenance

7.1 Common Equipment Maintenance Process

(1) **Regularly maintenance of the tube:** when not in use for a long time, please drain the liquid in the peristaltic pump tube in time, open the peristaltic pump protection lock, and loosen the peristaltic pump tube.

(2) **Regularly check the pipe connector:** regularly check whether the connectors are loose or damaged. If there is an abnormality, it must be replaced in time.

7.2 Common Problems and Solutions

Problem	Problem description	Solution
The fan does not turn.	Too much dust on the fan causes stoppage	Remove the dust with soft brush after power down
	The fan is broken or the fan power supply is not in good contact.	Return it to factory for repair.
The motor does not rotate.	The screen displays the speed and the running light is always on, but it does not actually rotate	Check whether the pump body connector is tight or not.
		Check whether the "Current code" in "Setting" is too small and set the current code consistent with the product.
		Motor connection wire is loose and return it to factory for repair.
		Motor power supply wire is loose and return it to factory for repair.
Motor is stalled.	The original valve head/tube can run at a certain speed, but the new valve head/tube cannot run.	The new valve head/tube needs to run for one or two minutes at a lower speed.
	Exceed the maximum speed of the valve head/tube.	Refer to the aforementioned running curve and select the suitable speed corresponding to the valve head/tube.
Flow is inaccurate.	The tube has been used for a long time and the resilience is reduced.	Replace the tube.
	Inappropriate accuracy requirements.	Flow rate/rotation speed/tube diameter is inversely proportional to accuracy. Under the working condition, try to use the tube with a smaller diameter.

Chapter 8 Version Description

Version	Description	Release time
V1.0	Original version	2020.12.20
V1.1	Add LM40A drawings and the command display format is changed from 00H to 0x00.	2021.04.22
V1.2	Add description of setting and control of the suction angle. Add description of external control mode/foot pedal control mode. Modify the actual corresponding table of current code and current.	2021.05.28
V1.3	Delete the two excess flow-speed curves and update the maximum flow rate value	2021.07.23
V1.4	Describe the current and communication parameters	2021.08.21
V1.5	Change external dimensions. Increase case options Increase flow rate of SN25-3 rollers/YZ2515-3rollers pump head Add multicast address, broadcast address command change parameter range in Address20 Add external control module wiring schematic Add suction angle command YZ1515X-3X flow rate changed same as LM60 1385 Update parameter values of pump head and pump tube	2021.10.13

Chapter 9 Technical Service



南京润泽流体控制设备有限公司
Nanjing Runze Fluid Control Equipment Co.,LTD

Tel : 025-51197362

Phone : 138 5195 4068

Fax : 025-51197362

Technical support : 183 5195 5944

Official URL : <http://www.runzefluid.com>

Alibaba Store URL : <https://runzeliuti.en.alibaba.com>

Sales Email : xiaoyan.xiang@runzeliuti.com

Address : NO.9 Tianxing West Road, Dongshan Street, Jiangning District,
Nanjing, Jiangsu, China



Official URL



Alibaba Store URL



Aliexpress Store URL